

DUMAG® Industrial Burner IB-r

**Burner with a round shut-off damper
Tightly sealed valves usable
For combustion air temperatures up to 200°C**

Multi-fuel burner for fuel gas, fuel oil, waste gas, waste oil

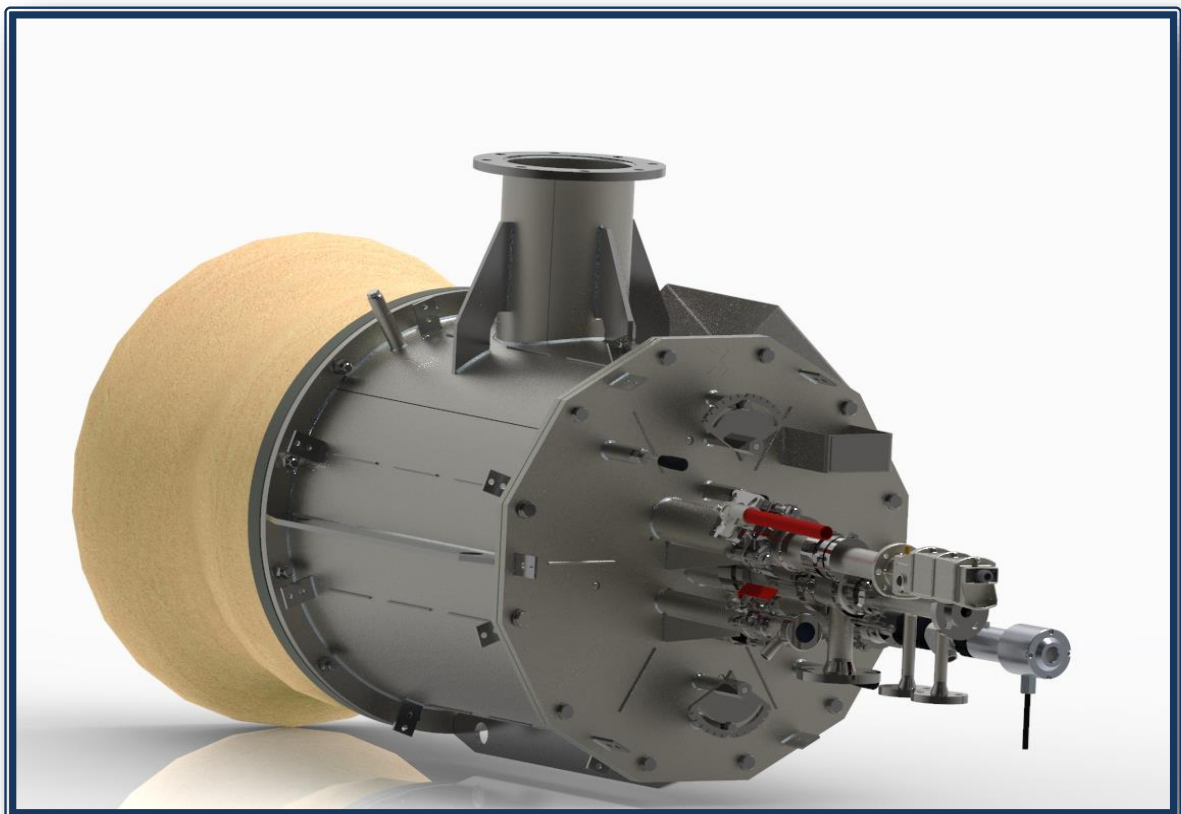

**General
Assembly
Description
Standards
Certificates
Material
Dimensions**

DUMAG® Industrial Burner IB-r

with round, tightly sealed shut-off damper for combustion air

Data sheet

1. General

Basically the DUMAG® Industrial Burner IB-r .. has the same structure as the DUMAG® Industrial Burner IB .., in contrast to this it has a tightly damper to control the combustion air.

The application area is like DUMAG® industrial burner IB .. in refractory lined combustion chambers of the pharmaceutical and chemical industries or in the rotary

rotary kiln etc.

In these areas very large control ranges and small loads are necessary so that used for these applications tightly sealed shut-off dampers are possible.

Small power ranges in the heating phase are therefore possible without any problems

2. Assembly

The heart of the DUMAG® Industrial Burner IB-r .. Is the same as in DUMAG® Industrial Burner IB .. the proven design of the swirl device to optimize the distribution of the combustion air with the fuel and to stabilize the flame.

The swirl device is a combination of an externally adjustable swirl body and a central axial air flow. Both airflows can also be varied with slider.

With this possibility of fine tuning the start-up time is reduced to a minimum.

On the burner front plate the adjusting device for swirling air flap (5) for the twist (5), the slider rod (9), the sight port (3), the pilot burner (4) and the flame detector (6) are mounted and are standard.

Depending on the application of the burner lances for liquid or gaseous media (1, 2) are used and mounted in the burner plate.

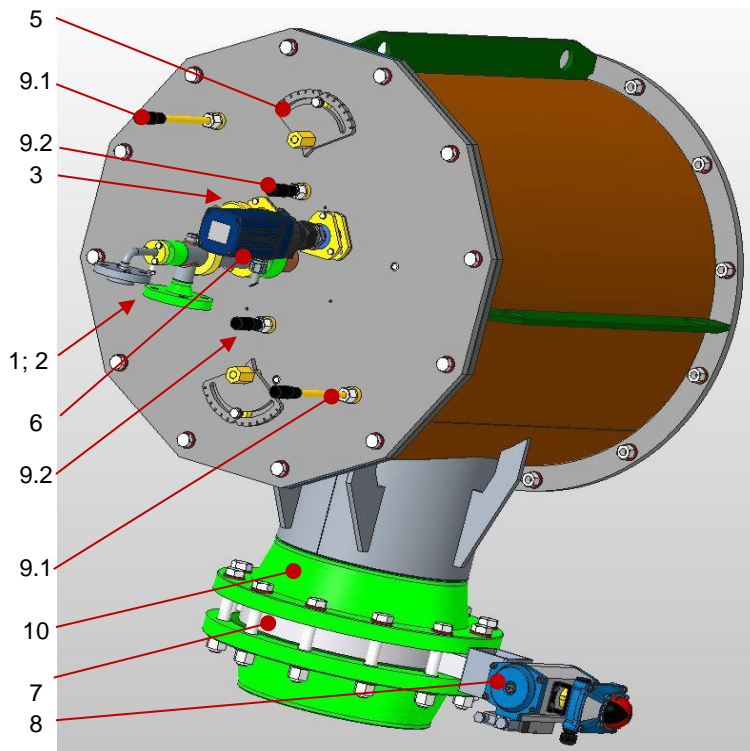

- 1 Burner lance
- 2 Gas lance GU
- 3 Sight port
- 4 Pilot burner (installed in the burner block or in burner, here not shown)
- 5 Adjusting device for swirling air flap
- 6 Flame scanner
- 7 Damper for combustion air (optional)
- 8 Actuator for air flap (optional)
- 9.1 Slider rod for swirl air
- 9.2 Slider rod for center air
- 10 Combustion air connection flange. Built as flat flange, EN-flange or ANSI-flange

Example, to designate a burner

IB-r800GGS

—	—	Liquid or gaseous media
—	..G	Gas burner for gaseous media with gas lance
—	..GG	Gas burner for gaseous media with 2 or more gas lances
—	..GS	Burner for liquid media with burner lance LS..GS and ultrasonic nozzle GS
—	..GGS	Burner for gaseous and liquid media
—	..GOS	Burner for 2 liquid media by use of lance LOO..GOS + triple media ultrasonic nozzle GOS..
—	..GGOS	Burner for gaseous and liquid media by use of triple media ultrasonic nozzle GOS..
—	800	... size of burner, see below
—	IB-r	... DUMAG® Industrial Burner with round, tightly sealed shut-off damper for combustion air

DUMAG® Industrial Burner IB-r

with round, tightly sealed shut-off damper for combustion air



Data sheet

3. Description

The DUMAG® Industrial Burner IB-r is a multifuel burner system for fuel gas, fuel oil, waste gas or waste liquid.

To ensure that the burner can be used universally, special attention has been paid to its functionality.

The combustion air in the burner is divided into two air streams, the unswirled central air and the swirl air, which flows around the central air in an axial direction into the combustion chamber.

The flow rates of both air streams can be individually adjusted using a slider.

The strength of the swirl can also be adjusted, as well as the rotational direction (clockwise or anticlockwise).

[Applied gas lance or burner lance for liquids \(1,2\):](#)

The different mass flows are supplied by burner lances for one or two liquids and gas lances GE or gas lances GU for fuel gas or waste gas (arranged centric or eccentric around the center)

[Additional devices](#)

To burn waste air or off gases additional the DUMAG® Gas Ring Distributor RVT or the DUMAG® Precombustion Chamber VBK with built in gas lances can be applied.

[Combustion air:](#)

What makes this burner special is the opportunity to use a tightly sealed combustion air flap (7) with a high control range and a small low-load range.

Combustion air temperatures up to 200 ° C, the max burner capacity is reduced according to the temperature.

For higher temperatures the DUMAG® Industrial Burner of the series .. IB must be used (square, not tight fitting lid)

[Sealing of penetrations into the burner](#)

The burner lances for gaseous or liquid media are sealed by stuffing boxes. The penetration for adjusting device for swirling air flap and slider rods are sealed with O-rings.

4. Applied standards, regulations and rules, depending on the design of the burner

EN 746-1	Industrial thermo processing equipment – Common safety requirements for industrial thermo processing equipment
EN 746-2	Industrial thermo processing equipment – Safety requirements for combustion and fuel handling systems
EN 12952-8	Water-tube boilers and auxiliary installations – Part 8: Requirements for firing systems for liquid and gaseous fuels for the boiler
EN 12952-16	Water tube boilers and auxiliary installations – Part 16: Requirements for grate and fluidized bed firing systems for solid fuels for the boiler
EN 50156-1	Electrical equipment for furnaces and ancillary equipment. (VDE 0116)
TRG	Technical Rules for Pressurized Gases
TRbF	Technical Rules for flammable liquids
97/23/EG	Pressure Equipment Directive
2006/42/EC	Machinery directive
API 535	Standard for burners for fired heaters in General Refinery Services
API 560	Standard for design and manufacture of fired heaters
API 660	Shell and Tube Heat exchangers for General Refinery Services.
ASME VIII/Div.1	American Boiler and Pressure Vessel Code. Regulation for Design and Construction
API RP 582	Recommended Practice and Supplementary Welding Guidelines for the Chemical, Oil, and Gas Industries
ASME B31.2 (NFP A223.1)	Regulation of Fuel Gas Piping
ASME B31.3	Regulation of Process Piping
ASME IX	Welding Qualifications
ASTM	Material Specifications
EAC	Euroasian Conformity

5. Certificates

certified according to ISO9001, EAC (Euroasian Conformity)

Produced according to European and American standards, regulations and quality certificates

6. Materials

- Burner housing: standard 1.4571 or 1.4404 (AISI316L/AISI316Ti), upon request P265GH or other materials on request.

Turned parts of stainless steel, at least the same quality as the burner.

- Burner lance: standard 1.4571 or 1.4404 (AISI316L/AISI316Ti), upon request Hastelloy or others.

- Nozzle: standard 1.4841 (AISI314 or AISI310), upon request 1.4571 or 1.4404 (AISI316L/AISI316Ti), Hastelloy

Components exposed to the radiation of the combustion chamber may also be made of 1.4841 (AISI314 oder AISI310).

Subject to change without notice

Vers.16

23.01.2021

DUMAG® Industrial Burner IB-r

with round, tightly sealed shut-off damper for combustion air

Data sheet



7. Dimensions

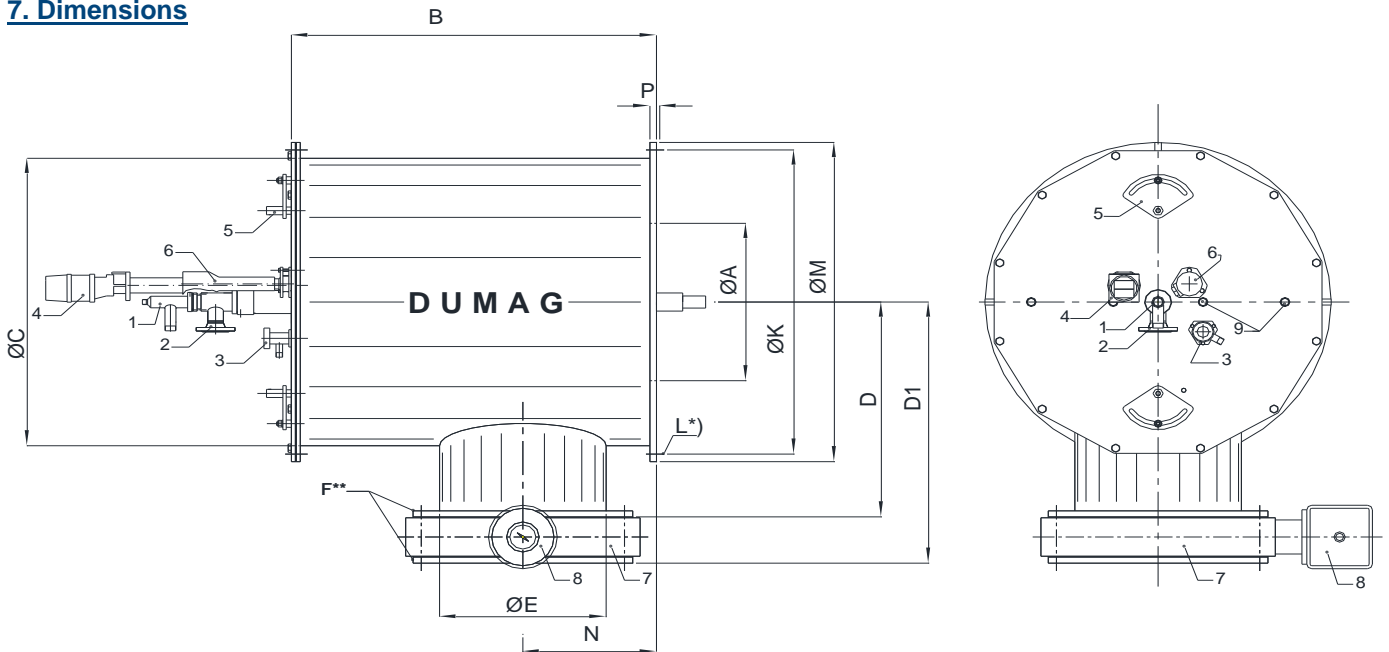

Type	Capacity	max. combustion air ¹⁾	ØA	B	ØC	D	D1	ØE	Flange F**	ØF	ØK	ØL*	ØM	N	P	Weight
	MW	Nm ³ /h	mm	mm	mm	mm	mm	mm	DN	mm	mm	mm	mm	mm	mm	ca. kg
IB-r100	1,2	1 500	165	530	350	364	438	139,7	125	240	390	12xØ14,5	430	167	12	
IB-r150	1,7	2 100	200	560	420	409	483	168,3	150	265	460	12xØ14,5	500	182	12	
IB-r250	3,0	3 700	240	615	506	500	578	219,1	200	320	546	12xØ14,5	586	210	12	
IB-r400	5,0	6 100	290	700	612	609	698	273,0	250	375	662	12xØ18,5	702	262	15	
IB-r600	7,0	8 500	355	750	700	654	753	323,9	300	440	750	12xØ18,5	790	278	15	
IB-r800	9,0	11 000	400	800	780	689	793	355,6	350	490	830	12xØ18,5	870	315	15	
IB-r1000	12,0	15 000	450	850	860	822	950	406,4	400	540	910	12xØ18,5	950	340	20	
IB-r1500	18,0	22 000	520	1 155	950	860	1 013	508	500	645	1 005	12xØ24	1 055	408	20	
IB-r2000	23,0	28 000	600	1 260	1 100	923	1 103	610	600	755	1 180	24xØ24	1 240	490	20	
IB-r2500	29,0	35 000	670	1 270	1 220	1 018	1 203	610	600	755	1 300	24xØ24	1 360	490	25	
IB-r3000	35,0	43 000	730	1 380	1 330	1 187	1 383	711	700	860	1 410	24xØ24	1 470	532	25	
IB-r4000	46,0	56 000	840	1 580	1 540	1 242	1 463	813	800	975	1 620	24xØ24	1 680	615	25	
IB-r5000	58,0	71 000	940	1 680	1 726	1 374	1 608	914	900	1 075	1 806	24xØ24	1 866	670	25	

*) size of screw and length see data sheet 43528 for burner block

**) Connection dimensions and bolt sizes according to EN 1092-1, PN10. Also available in ANSI 150 lbs or other

1) with combustion air temperatures above 100 °C the values + 10% also apply to operating m³/h

- 1 Burner lance
- 2 Gas lance GU
- 3 Sight port

- 4 Pilot burner
- 5 Adjusting device for swirling air flap
- 6 Flame detector

- 7 Flap for combustion air (optional)
- 8 Actuator for air flap (optional)
- 9 Slider rods

Cover picture: Burner designed for hot combustion air. Burner prepared for external insulation.

Subject to change without notice

Vers.16

23.01.2021